



**The Public Safety Broadband Wireless Network:
21st Century Communications for First Responders
Public Safety Homeland Security Bureau
Federal Communications Commission
Tuesday, March 9, 2010**

Agenda

- Introduction and Purpose
- Overview of the NBP
- Network Model and Assumptions
- Cost Model
- Priority Access
- Device Ecosystem and User Performance
- Deployables
- NYC Analysis Discussion
- Summary



Broadband Network Strategy

Vision: For significantly less than what has been spent on narrowband interoperability, a new interoperable broadband network will be deployed using commercial technologies, bringing public safety communications into the 21st Century

Administrative and Technical Regime	ERIC	Funding
<ul style="list-style-type: none"> • Authorized network operators will deploy and operate the PS BB network in partnership with commercial entities (RFP approach) (or on their own) • PS access to roaming and priority access on commercial networks • Improves redundancy and resiliency • D block licensed for commercial user • Competitive options for incentive-based partnerships • User device requirements 	<ul style="list-style-type: none"> • Establish framework for interoperability and operability requirements • Avoids fragmented networks of the past 	<ul style="list-style-type: none"> • Fund network construction, operation, and evolution • Nationwide availability • Hardened network • Grants for cap ex • PS BB fee to fund op ex



Benefits of Incentive-Based Partnership Approach

- ✓ Increased redundancy and reliability
- ✓ Improved capacity and performance for Public Safety
- ✓ Reduced costs for PS agencies and state and local governments
- ✓ Improves commercial infrastructure and reach
- ✓ Transition path to increased spectrum and operational efficiency
- ✓ Enable public safety to evolve with commercial technology, applications, and devices improvements (evergreen)



Public Safety Network and Solutions

Solution for **Reliable, High Coverage Mission Critical** Voice, Data, & Video 4G Services

Deployable Equipment Caches

For exceptional times and places when PS & commercial infrastructure is insufficient

DAS and Microcell Systems In-Building/Underground Coverage

Coverage deep inside large buildings and capacity for high pedestrian density (e.g., shopping centers) can only be provided by in-building solutions

Commercial Wireless Networks Roaming and Priority Access

Provides access to additional capacity during emergencies, as well as increased network resiliency

Public Safety Broadband Wireless Network Public Safety's Dedicated Network

Enables high coverage communications, resilient coverage and guaranteed access



Complementary Strategies for Existing Network Footprint and Rural Areas

- **Overlay the Commercial LTE Network to 95% of the Population**
 - 41,000 cell towers to achieve the capacity demanded by 290 million subscribers
 - Public safety can use and harden these same towers to achieve excellent coverage and signal reliability for a much smaller number of users
 - Public safety transceivers will be placed on up to 41 K commercial towers.
 - Providers will compete to provide this service
 - Public safety mobile devices will be hardened versions of commercial handheld devices to reduce costs and increase functionality
- **For the most rural remaining 5% build a vehicular LTE network**
 - Public safety will use and harden LMR or other towers where available, and will supplement with new towers where needed
 - To reduce number of rural towers needed, mobile devices in rural areas will have externally mounted antennas as is common today
 - In-door coverage improved through “relays” placed in emergency vehicles



General Assumptions for Cost Model

■ **OVERALL SERVICE AND BUILD ASSUMPTIONS**

- ❑ Supports high quality wireless broadband service with dedicated spectrum for PS in near term and mission critical voice, data, and video service in long term
- ❑ 5 + 5 MHz PS BB spectrum lit-up exploiting commercial infrastructure
- ❑ Subscriber device model: Commercial power levels (23 dBm) and internal/external antenna, except for highly-rural which uses same power over External Antenna Mount (EAM). Device funding not-included
- ❑ In-building coverage from base station is as good or better than commercial LTE, consistent with NPSTC and PSST recommendations, except for highly-rural (<5% on density) which uses vehicular External Mount Antenna (EMA) to improve coverage
- ❑ LTE commercial roll-out availability to 95% POPS will be achieved by market forces by 2015
- ❑ LTE Commercial Speeds with 95% area coverage (256 Kbps uplink) can be achieved built on top of LTE commercial service cell site infrastructure with minimal site supplementation can be achieved except for highly-rural. Model to be refined based on real-life experience in future grant years
- ❑ Vehicular coverage for highly-rural to achieve 99% POP coverage
- ❑ Data and Video Services via IP Transport in early years offering more reliable version of public safety wireless aircard services, evolving to target of interoperable Mission Critical voice, data, and video IP networks and applications as long term target



General Assumptions for Cost Model (con.)

■ CAPEX

- Grant funding for RFP based on commercial entity, installing and operating dedicated PS BB 700 MHz RAN and sharing backhaul, IP Core transport systems including ancillary and support systems and services.
- Grant based on full costs of dedicated RAN build. Does not discount prices for competitive bidding dynamics including strategic value to bidders.
- Cell sites in rural America treated as blended build of new sites on existing structures and new sites.

■ OPEX

- Annual opex fee incurred for management and maintenance of PS 700 MHz BB RAN. Backhaul, core network, and Managed IP Services and Ancillary Services provided via wireless operator or systems integrator and paid through opex charged for Managed Services Fee.
- Managed service fee based on today's aircard managed service fee structure with RAN share of service eliminated.

■ PRIORITY WIRELESS BROADBAND SERVICE

- Priority wireless service on commercial networks, deployables and in-building supplementation provides for capacity surges, more extensive coverage, and more resiliency thus lowering site requirements on core network. Operators will recover costs through charges at favorable commercial rates.



Example Public Safety / Commercial Base Station Configurations

- Depending on Public Safety / Commercial agreements, more active sharing than shown may be possible

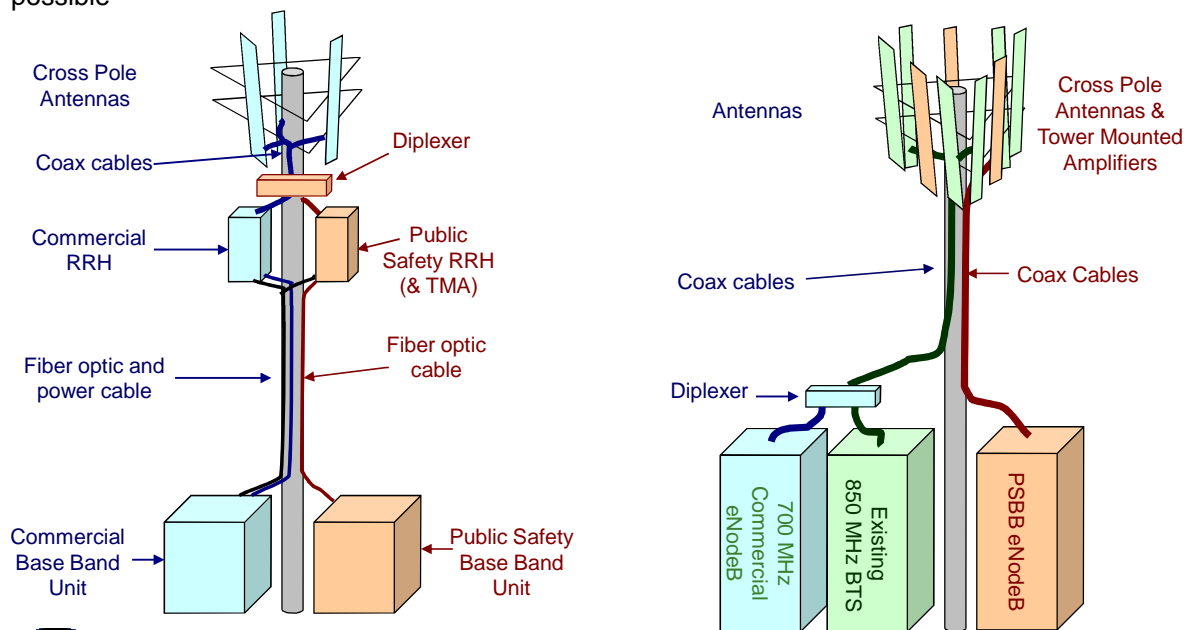

Other bands supported by commercial operator not shown



Operating Model Assumed for Network Costing

 = Assumed Model

Infrastructure Oriented ← → **Service Oriented**

	Dedicated Network	Dedicated Radio Access Network	Dedicated Channel	Fully Shared, Enterprise	Fully Shared, Retail
<i>Description</i>	<ul style="list-style-type: none"> PS has separate base stations, backhaul and core network 	<ul style="list-style-type: none"> PS has separate base stations, uses carrier core network 	<ul style="list-style-type: none"> PS uses carrier RAN and core, with line card for PS spectrum 	<ul style="list-style-type: none"> PS uses carrier network for data transport, adds service layer 	<ul style="list-style-type: none"> PS relies on carrier network for data transport and services
<i>Business Model</i>	<ul style="list-style-type: none"> Contract to build and manage network 	<ul style="list-style-type: none"> Contract for RAN OA&M Tonnage fees for core services 	<ul style="list-style-type: none"> Install subsidy for channel card Tonnage fees for core services 	<ul style="list-style-type: none"> Tonnage fees 	<ul style="list-style-type: none"> User / service fees
<i>Advantages</i>	<ul style="list-style-type: none"> Maximum PS control, flexibility, and dedicated capacity 	<ul style="list-style-type: none"> PS can specify RAN req's, dedicated RAN capacity 	<ul style="list-style-type: none"> Dedicated RAN capacity, cost-efficient 	<ul style="list-style-type: none"> High cost efficiency, service level flexibility 	<ul style="list-style-type: none"> High cost efficiency, operational simplicity
<i>Disadvantages</i>	<ul style="list-style-type: none"> High PS cost and complexity 	<ul style="list-style-type: none"> RAN cost redundancies 	<ul style="list-style-type: none"> Some limits on feature flexibility 	<ul style="list-style-type: none"> No dedicated capacity 	<ul style="list-style-type: none"> No dedicated capacity, less service flexibility, higher user fees



Validation of Model

- ✓ Constructed detailed RF model
- ✓ Validated RF assumptions through technical analysis including data from vendors and carriers
- ✓ Costs based on tariff rates, actual proposals from carriers, and information obtained from carriers and vendors
- ✓ Developed cost scenarios
- ✓ Validated cost scenarios with major carriers and equipment vendors



Cost Model Details

- **CAPEX**
 - **Building Public Safety 700 MHz BB Spectrum Network**
 - 95% POPS (dense urban to moderate rural) buildout
 - Hardening the 99% POPS network
 - Highly rural (95% to 99% of POPS)
 - Deployables
 - Excluded - devices
- **OPEX**
 - Cell site OA&M
 - Transport and IP Managed Services
 - Additional Rural Costs and Miscellaneous
 - Excluded – priority access and roaming, in-building



General Cost Model Assumptions

- **5x5 MHz of dedicated spectrum lit-up exploiting commercial infrastructure to achieve a high quality wireless broadband service, supporting voice, data and video.**
- **Subscriber devices have commercial power levels of 23dBm, except for highly rural areas which use EAM.**
- **In-building penetration losses same as commercial LTE, except for highly rural areas which use EAM.**
- **LTE commercial speeds with 95% coverage area (256 Kbps uplink).**



Device Ecosystem

- There is a great opportunity with LTE to leverage commercial economies of scale on those parts that add the most cost to devices
- Therefore public safety devices will be close to the cost of unsubsidized commercial devices

Component ⇒	Hardware	Software/ Middleware	Operating System	Baseband Chipset	RF Chipset	RF Front End
Degree of commonality to commercial devices	Medium	Medium	100%	100%	100%	Low
Effect of customization on cost	Low	Medium	High	High	High	Low

Cost of customizing the highest cost components will NOT be incurred because they are 100% leveraged



Priority Access and Roaming

- The LTE standard includes a flexible priority mechanism that can be configured to meet any public safety need.
- Technology
 - LTE **Allocation and Retention Priority (ARP)**
 - Used to accept/modify/drop bearers (applications/users) in case of resource limitations
 - At the beginning of a session, packets immediately receive the designated of packets from existing consumer data sessions
 - Signaling priority
- Reaching Agreement
 - FCC will work with public safety, commercial wireless carriers and vendors to determine precise needs, and how systems should be configured to meet those needs



Deployables

- **\$200 M program to provide development and initial deployment to support two use cases**

- **Fleets for Mobile Cell Site Deployment**
 - Provides for PS BB Spectrum coverage where no cell sites
 - Remote areas such as wilderness
 - Replacement of cell site(s) destroyed by disaster
 - Supplemental coverage for long-term major incidents
 - Fleets on regional/state basis to provide coverage w/in a few hours

- **Vehicular Area Networks**
 - Equips vehicles with “relay capability” so first responders can leave vehicle with handheld and use vehicle to communicate to PS BB network
 - Enhance coverage into buildings
 - Extends coverage from vehicle to surrounding area



Summary

- Ensures that broadband wireless communications for public safety will be fully interoperable across all geographies and jurisdictions
- Ensures nationwide coverage
- Provides for funding for the construction, operation and evolution of the public safety network
- Provides for reserve capacity and needed redundancy and reliability through roaming and priority access on commercial broadband networks
- Ensures that public safety will have handsets available at consumer electronic prices

